

- A: Intonation adjustment screw
- B: Saddle height adjustment screw (1.5mm hex key wrench)
- C: Slide-able saddle lock screw (1.5mm hex key wrench)

- D: Tuning knob (can also be turned with screwdriver)
- E: Ball end holder
- F: String locking screw (2.5mm hex key wrench)
- G: String locking pin

MR5HS

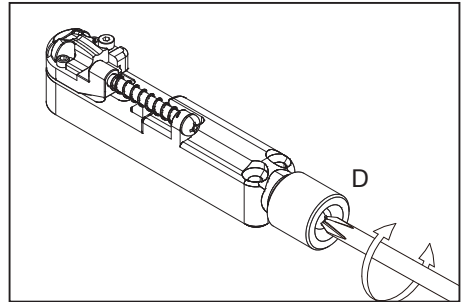
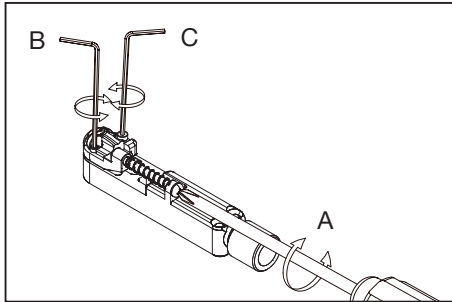

STRING REPLACEMENT

MR5HS

- ① Turn the tuning knob till the ball end holder(E) reaches the loading position.
- ② Mount the ball end of the string below the catch of the ball end holder.

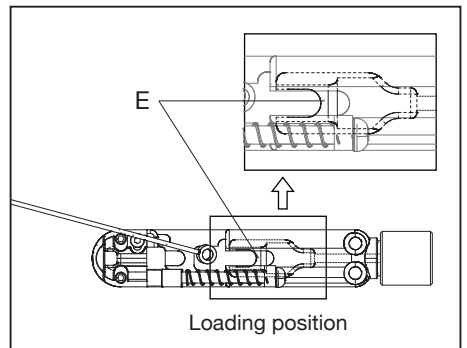

Head Piece

- ① Thread the string through the string hole and pull it tightly.
 - ② To lock the string in place, tighten the string locking screw (F).
- ※ Please insert the string locking pin (G), rounded end first.
 - ※ Avoid overtightening to prevent damaging the string.

