

STD-DL tremolo bridge

■ Overview

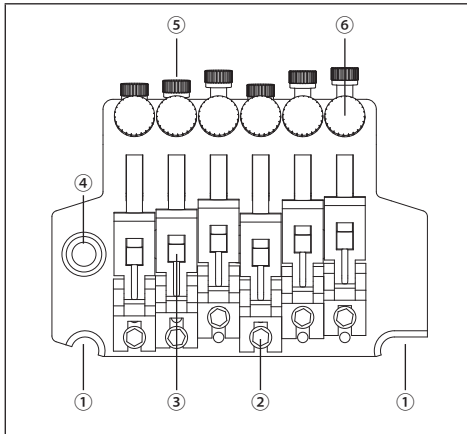

- ① knife edge
- ② saddle lock bolt
- ③ string holder block
- ④ tremolo arm socket

■ Rear

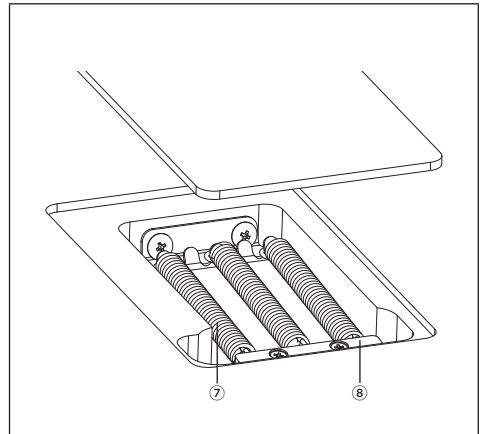

- ⑤ string stopper bolt
- ⑥ fine tuning bolt
- ⑦ tremolo spring
- ⑧ spring lock

EN

ATTACHING THE TREMOLO ARM

- ① The tremolo arm employs a one-piece snap-in design with an adjustable-torque cap. Insert the tremolo arm into the arm socket of the base plate.
- ② Tighten the torque adjustment cap to secure the tremolo arm. The tremolo arm will become tighter as you tighten the torque adjustment cap.

ADJUSTING THE TREMOLO ATTACHMENT ANGLE

The tremolo attachment angle is adjusted by changing the balance between the string tension and the tension of the tremolo springs installed on the back of the guitar body. You'll obtain the optimal performance by adjusting this so that the tremolo is approximately horizontal to the surface of the guitar body.

- ① With the guitar tuned correctly, check the angle of the tremolo.
- ② If the tremolo is tilted toward the front, insert a Philips screwdriver through the slit in the tremolo spring cover on the back of the body, and tighten the screw to increase the tension of the tremolo springs.
- ③ If the tremolo is tilted toward the rear, loosen the screw to decrease the tension of the tremolo springs.

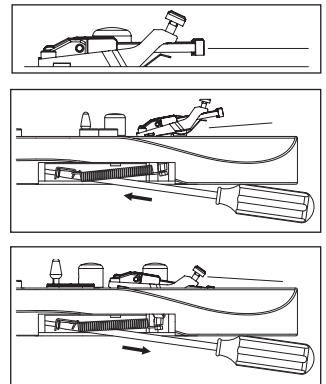

※ The tremolo angle adjustment will affect the tuning, because the balance of tension between the strings and the springs will change each time you adjust the tension of the tremolo springs. You'll need to tune repeatedly while making this adjustment.



TREMOLO SPRINGS

When the guitar is shipped from the factory, it is set up with three tremolo springs installed in parallel.

If the balance of tension between the strings and the tremolo springs has changed significantly, such as when you've switched string gauges or are using a dropped tuning, you may need to change the number of tremolo springs or change the way in which they are installed.

- ① If you want to increase the tension, install the outer two tremolo springs diagonally.
- ② If you want to decrease the tension, remove the center tremolo spring.

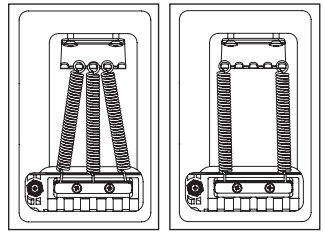

Memo

- Loosen the strings sufficiently before you install or remove tremolo springs. Be aware that if you remove all of the springs, the tremolo unit will detach from the guitar.
- To reattach the tremolo, insert the knife edge of the tremolo securely into the groove of the stud bolts, and then install the tremolo springs.

ADJUSTING THE ACTION

To adjust the height of the entire tremolo unit, use an HEX key wrench (3mm) to turn the stud bolts located at the left and right of the tremolo unit. (It is not possible to make adjustments for each string individually.)

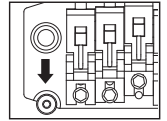

ADJUSTING THE INTONATION

- ① Use an HEX key wrench (3 mm) to loosen the pressure pad bolts of the nut, and loosen the strings sufficiently.
- ② Use an HEX key wrench (2 mm) to loosen the saddle lock bolts, and adjust the saddle position.

※ Before checking the intonation, firmly tighten the saddle lock bolts and tune the guitar correctly. When you've finished making adjustments, tighten the saddle lock bolts and the pressure pad bolts of the locking nut.

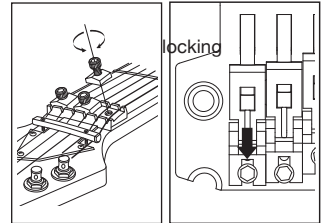

REPLACING THE STRINGS

- ① Use an HEX key wrench (3 mm) to loosen the pressure pad bolts of the locking nut, and remove the string from the tuning peg.
- ② Use an HEX key wrench (3 mm) to loosen the string stopper bolt of the tremolo unit; then pull the string out of the saddle and remove it.
- ③ Use wire cutters to cut off the ball end of the new string.
- ④ Insert the tip of the string from which you cut off the ball end between the saddle and the string holder block, and tighten the string stopper bolt to fasten the string.
- ⑤ Wind the string onto the tuning peg, and tune it.
- ⑥ When you've finished tuning, tighten the pressure pad bolts of the locking nut.

※ Removing all strings at the same time will cause the tremolo attachment angle to change significantly, so we recommend that you replace the strings one at a time. If you remove all strings at the same time, tuning will be easier if you wedge a piece of cloth below the tremolo to secure it so that the tremolo attachment angle won't change significantly.

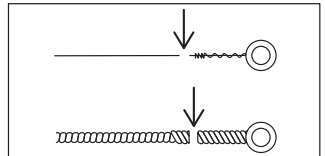
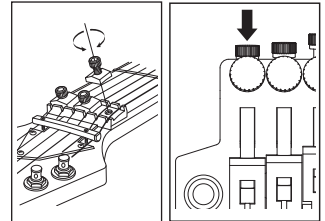

Memo

- Before you tune, make sure that the string stopper bolts are firmly tightened.

FINE TUNING

Even after you've used the locking nuts to lock the strings, you can use the fine tuners to fine-tune each string. The range of adjustment after the strings are locked will be widest if you leave all fine-tuning bolts near the center of their adjustable range before you tune.

